



A.G. Engineering

Auto Glass Engineering



The AG-H is a fully automatic long edge screen-printing machine.

The machine is composed of two sections:

- a - The printing head
- b - The transportation system and printing table

- a - Printing head

Main features:

Horizontal raising and lowering.

The screen is held horizontal during the flooding operation.

Pneumatic operated squeegee / flood coater change over.

Pneumatic squeegee pressure adjustment

Mechanical flood coater height adjustment

Automatic peel-off.

Pneumatic screen locking device.

Adjustable printing stroke length by means of sliding proximity switches

Choice of flooding before or after the printing stroke

Squeegee carriage moves on Rollon linear bearings, driven by AC inverter controlled motor.

The squeegee and the flood coater are independently adjusted for speed.

Fine registration adjustment $\pm .10$ mm.

Pneumatic squeegee pressure equalizer.

Pneumatic screen clamping.

Ink Scooping device. The squeegee and the flood coater can be swung close to form a scoop that hold the ink, avoiding any dripping on the printing table, when the screen is serviced or removed.

b Transportation system and printing table

Main characteristics:

The unit has an independent glass transport system with round belts moved by an A.C. inverter motor control. During the glass transportation the belts are raised about 5 mm above the printing table surface. When the transportation is completed the belts are lowered into the printing table track.

On the printing station the glass is accurately registered as follows: the side closing plates and 3 pins for the front and back edges will register the part. The registration device is self-adjusting: it closes always toward the machine center regardless to the dimension involved.

The registration device open and close about 100 mm from the edge position: that allows the incoming part to be offset (+/- 50 mm max).

The side plates also prevent possible screen damage from the glass edge.

The printing table is made of flat aluminum.

After printing operation completion, the belts raise and the printed glass is conveyed to the exit, while a new glass is moved to the printing table.

The printing head supported by four massive posts, perpendicular to the printing table is raised and lowered through a new lifting mechanism (no chains are used).

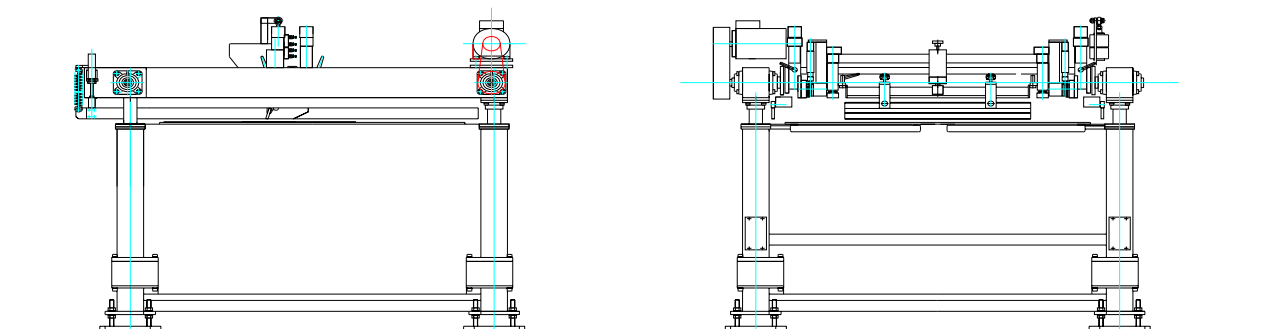

MODEL	UNIT	700 x 900	750 X 1000	700 x 900 con Master Frame
Max. Frame size	mm	1100 x 1430	1150 X 1650	1100 x 1430
Max glass size	mm	700 x 900	750 X 1000	700 x 900
Min glass size	mm	150 x 200	180 x 250	150 x 200
L1	mm	1940	2000	1940
H printing line	mm	975	975	975
L2	mm	1700	1800	1700
H MAX	mm	1500	1500	1500
Glass thickness	mm	3/12	3/12	3/12
Cycle / h	N°	360	360	360
Compressed air lt/h	N lt/1'	50	50	50
Corrent rating	KW	6	8	6
Weight	Kg	1000	1100	1100

A.G.Engineering s.r.l.

Via Colleoni 3 – Palazzo Taurus Ing. 2

20041 Agrate Brianza (MI) - Italy

Tel.+39-039-6892633 – Fax. 6892642

E-mail: agengineering@tin.it

Web site: www.agengineering.it